

FABRIQUÉ
EN FRANCE



French manufacturer
of gardening equipment

www.mvindustrie.fr

Catalog



MV INDUSTRIE is a family-owned plastics company, established in the Drôme since 1994, specialising in the manufacture of ingenious products for the garden and home.

In 2023, we are celebrating 20 years of success of our famous rigid tunnel  which is used to force and protect crops in the vegetable garden.

For this anniversary,  becomes 

Thanks to this success, we strive to regularly offer you new, innovative and clever products to make your daily life easier.

You can discover them in the pages of this new catalog!

SUMMARY

- P. 2** : To know us / Summary
- P. 3** : Modulo 30 Tunnel and accessories
- P. 4-5** : Modulo 40 Tunnel and accessories
- P. 6-7** : Modulo 60 Tunnel and accessories
- P. 8-9** : Moduloplak, rigid and durable mulch
- P. 10-11-12-13** : Modulo 35 Cloche, extension height and mini stakes
- P. 14-15** : Mikado planting marker
- P. 16-17-18-19** : Mikado garden stakes
- P. 20-21** : Kajo 4 l. basket
- P. 22-23** : Kajo 15 l. basket
- P. 24-25** : Kajo 20 l. basket
- P. 26-27** : Wheel trolley Kaba for Kajo 15 l.
- P. 28** : Bike basket holder for Kajo 15 l.
- P. 29** : Compost bucket Kajo
- P. 30-31-32-33** : Calipso planter and window box
- P. 34-35** : Garden tools kit Calipso
- P. 36-37** : Elevation kit for Calipso planter
- P. 38-39** : Richel garden greenhouse
- P. 40** : Contacts and adresse

Our profession :

Plastic injection.

- 5 300 m² premises.
- 1993-2002 = various sub-contracting.
- Since 2003 = supplier of garden centres and integrated with our products.
- 1800T - 900T - 320T - 100T injection moulding presses and renowned expertise.

Our commitment to responsible manufacturing :

- 100% recyclable plastic materials and/or compliant with food standards.
- Re-purposing of various waste products.
- Green energy agreement.
- All moulds designed and manufactured in France.
- All products manufactured, assembled and shipped on site.
- Local or regional suppliers, sub-contractors and partners.

Our commitment to responsible distribution :

- Show-room so you can test, assemble, handle and try out our products.
- After sales service, advice and customer assistance with a simple phone call.
- The creation of multi-purpose, ingenious and durable products - high-quality and UV-resistant plastic.



Tunnel & Accessories

Modulo³⁰



Description : Mini greenhouse of stiff FORCING. Anchoring to ground via system of stakes, 2 offered by tunnel (POM). Integrated water collection tray. Flexible, rigid and stackable .

Product benefits : PROTECT AND ACCELERATE the grow of the sowing. MOVE FORWARD the harvests. ADAPT AND ORGANIZE the various sizes Modul'o according to yours plantations.

Material : Polypropylene  
Color : Transparent
Origin : FRANCE
Guarantee : 5-years anti-UV
Period of use : ALL YEAR

Barcode : 3 557400 012111

Unit weight : 1.290 Kg



Unit dimensions : 78 x 29 x 28

Reference : 001 211

+ 2 (INCLUSIVE)
OFFERED STAKES



Application : ideal for a row of sowing (salads, strawberries, radish, etc.).



PACKAGING	UVC PACKAGE	PACKAGE WEIGHT	PACKAGE DIMENSIONS	NO PKG / PALETTE	NO PKG / LAYER	NO LAYER / PALETTE	PALETTE WEIGHT	PALETTE DIMENSIONS	UVC PALETTE	PACKAGING PHOTOS
DISPLAY BOX 30 TUNNELS	30	41 kg	80 x 59 x 97 cm	2	2	1	92 kg	120 x 80 x 107 cm	60	
BOX 20 PAIRS OF END TUNNELS	20	4.25 kg	28 x 28 x 29.5 cm	24	8	3	120 kg	120 x 80 x 195 cm	480	

Tunnel end pieces x 2



Description : Essential accessories for modul'o 30 tunnel.
 1 component for each end to place on each side of the tunnel.
 Rigid and interlocking.

Product benefits : PROTECTING AND WINTERING tall unit plants.

Material : Polypropylene  
Color : Transparent
Origin : FRANCE
Guarantee : 5-years anti-UV
Period of use : ALL YEAR

Barcode : 3 557400 012210

Unit weight : 0.2 Kg

Unit dimensions : 28 x 28 x 1.9 cm

Reference : 001 221

Application : a pair of tips for several meters of protection.



Scan the QR code on the back of the catalog for more information.

FABRIQUÉ EN FRANCE 



Tunnel Modulo₄₀

Description : Rigid mini **FORCING** greenhouse. Length 1 m, width **40** cm.
Anchors to ground via system of stakes (sold separately)
Integrated water collection tray.
Modular, sturdy, stackable.

Product benefits : **PROTECTS AND ACCELERATES** seedling growth.
Helps crops to grow.

Material : Polypropylene  
Color : Transparent
Origin : FRANCE
Guarantee : 5-year anti-UV
Period of use : ALL YEAR

Application : Ideal for **one** row of seedlings (salads, raspberries, radishes, etc.).

Accessories : stakes and end pieces sold separately



Barcode : 3 557400 002105

Unit weight : 1.80 Kg

Unit dimensions : 105 x 39 x 30 cm

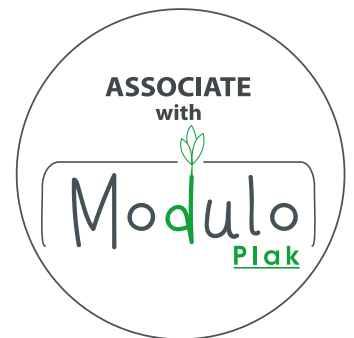
Reference : **PV 000 210**



PACKAGING	UVC PACKAGE	PACKAGE WEIGHT	PACKAGE DIMENSIONS	NO PKG / PALETTE	NO PKG / LAYER	NO LAYER / PALETTE	PALETTE WEIGHT	PALETTE DIMENSIONS	UVC PALETTE	PACKAGING PHOTOS
DISPLAY BOX	50	97 kg	107 x 80 x 152 cm	1	1	1	112 kg	120 x 80 x 167 cm	50	
DISPLAY BOX	30	60 kg	107 x 80 x 102 cm	1	1	1	75 kg	120 x 80 x 117 cm	30	
	10	20 kg	107 x 40 x 77 cm	5	2/1	3	115 kg	120 x 80 x 194 cm	50	
BOX	10	20 kg	107 x 40 x 77 cm	5	2/1	3	115 kg	120 x 80 x 194 cm	50	

Tunnel end pieces x 2

Description : Essential accessories for modulo 40 tunnel.
1 component for each end to place above and below tunnel.
Rigid and interlocking .

Product benefits : **SEALS OFF** tunnels.
Optimises protection for your plants.

Material : Polypropylene  
Color : Transparent
Origin : FRANCE
Guarantee : 5-year anti-UV
Period of use : ALL YEAR

Barcode : 3 557400 172204
Weight of the pair : 0,420 Kg
Dimensions of the pair : 37 x 5 x 28 cm
Reference : **PV 017 220**



Application : One pair of end pieces for several metres of protection.

PACKAGING	UVC / PACKAGE	PACKAGE WEIGHT	PACKAGE DIMENSIONS	NO PKG/ PALETTE	NO PKG / LAYER	NO LAYER / PALETTE	PALETTE WEIGHT	PALETTE DIMENSIONS	UVC / PALETTE	PACKAGING PHOTO
BOX	10	4.5 kg	39 x 30 x 35 cm	32	8	4	159 kg	120 x 80 x 155 cm	320	

Stakes for tunnel x 10

Description : Length 25 cm, pointed tip.
Dual-use head : large hook for ground anchoring, small hook for better tunnel ventilation.
Sold in packs of 10. Resistant and practical

Product benefits : **MULTIPURPOSE.**
Hose pipe support. Anchors to ground.

Material : Polyamid  
Color : Light green
Origin : FRANCE
Guarantee : 5-year anti-UV
Period of use : ALL YEAR

Barcode : 3 557400 002808
Weight of pack : 0.20 Kg
Dimensions of pack : 17 x 5 x 37 cm
Reference : **PV 000 280**



Application : 1 pack of 10 stakes for 2 to 3 tunnels.

PACKAGING	UVC / PACKAGE	PACKAGE WEIGHT	PACKAGE DIMENSIONS	NO PKG/ PALETTE	NO PKG / LAYER	NO LAYER / PALETTE	PALETTE WEIGHT	PALETTE DIMENSIONS	UVC / PALETTE	PACKAGING PHOTO
BOX	10	2.5 kg	36 x 36 x 13 cm	72	6	12	187 kg	120x80 x 171 cm	720	



Scan the QR code on the back of the catalog for more information.



Tunnel Modulo₆₀

Description : Rigid mini CROP greenhouse. 80 cm long, width 60 cm. Removable trap door with support leg. Anchored to the ground by a system of pegs (sold separately). Integrated water collection tray. Modular, solid and stackable.

Product benefits : PROTECTS AND ACCELERATE seedling growth. Helps crops to grow.

Material : Polypropylene  

Color : Transparent

Origin : FRANCE

Guarantee : 5-year anti-UV

Period of use : ALL YEAR



Application : Ideal for two rows of seedlings (tomatoes, peppers, zucchini, eggplants, etc.).

Accessories : stakes and end pieces sold separately

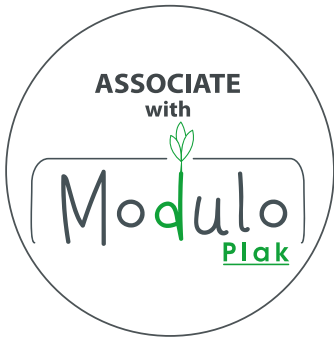

Barcode : 3 557400 114 105
 Unit weight : 2.65 Kg
 Unit dimensions : 79 x 59 x 50 cm
 Reference : PV 011 410



PACKAGING	UVC PACKAGE	PACKAGE WEIGHT	PACKAGE DIMENSIONS	NO PKG / PALETTE	NO PKG / LAYER	NO LAYER / PALETTE	PALETTE WEIGHT	PALETTE DIMENSIONS	UVC PALETTE	PACKAGING PHOTOS
DISPLAY BOX	10	30 kg	80 x 60 x 100 cm	2	2	1	75 kg	120 x 80 x 115 cm	20	
BOX	5	15.5 kg	80 x 60 x 74 cm	6	2	3	94.5 kg	120 x 80 x 163 cm	30	

Tunnel end pieces x 2

Description : Essential accessories for modulo 60 tunnel.
1 component for each end to place above and below tunnel.
Rigid and interlocking.

Product benefits : **SEALS OFF** tunnels.
Optimises protection for your plants.

Material : Polypropylene  
Color : Transparent
Origin : FRANCE
Guarantee : 5-year anti-UV
Period of use : ALL YEAR

Barcode : 3 557400 114204
Weight of the pair : 1.20 Kg
Dimensions of the pair : 56 x 4 x 49 cm
Reference : **PV 011 420**



Application : One pair of end pieces for several metres of protection.

PACKAGING	UVC PACKAGE	PACKAGE WEIGHT	PACKAGE DIMENSIONS	NO PKG / PALETTE	NO PKG / LAYER	NO LAYER / PALETTE	PALETTE WEIGHT	PALETTE DIMENSIONS	UVC PALETTE	PACKAGING PHOTO
BOX	5	7 kg	57 x 50 x 21 cm	20	1	20	155 kg	120 x 80 x 162 cm	100	

Stakes for tunnel x 10

Description : Length 25 cm, pointed tip.
Dual-use head : large hook for ground anchoring, small hook for better tunnel ventilation.
Sold in packs of 10. Resistant and practical

Product benefits : **MULTIPURPOSE.**
Hose pipe support. Anchors to ground.

Material : Polyamid  
Color : Light green
Origin : FRANCE
Guarantee : 5-year anti-UV
Period of use : ALL YEAR

Barcode : 3 557400 002808
Weight of pack : 0.20 Kg
Dimensions of pack : 17 x 5 x 37 cm
Reference : **PV 000 280**



Application : 1 pack of 10 stakes for 2 to 3 tunnels.

PACKAGING	UVC / PACKAGE	PACKAGE WEIGHT	PACKAGE DIMENSIONS	NO PKG / PALETTE	NO PKG / LAYER	NO LAYER / PALETTE	PALETTE WEIGHT	PALETTE DIMENSIONS	UVC / PALETTE	PACKAGING PHOTO
BOX	10	2.5 kg	36 x 36 x 13 cm	72	6	12	187 kg	120x80 x 171 cm	720	



Scan the QR code on the back of the catalog for more information.



Rigide and durable mulch x 2



Description : Rigid growing and mulching plate with 2 holes in the centre to place the the centre to place the plant and small perforations in a «drip» fashion to ensure the drainage of water towards the plantations.

- Replaces mulch film
- Prevents hoeing and weed growth by limiting the passage of light.
- Repels pests that attack crops.
- Limits temperature differences between day and night.
- Drains rainwater to the plants.
- Reduces watering, which saves water.
- Prevents the soil from drying out and keeps the soil moist and loose.
- Recyclable, stackable, interlocking, modular (easy to install and can be used to cover small or large areas).
- Brown colour, it adapts perfectly to the environment.

Product benefits :

Adaptable with Modulo 40 and 60 tunnels, pipes or micro-porous (ø 13 to 16 mm) and stakes for better ground support (sold separately).
2 plugs included to close unused areas.

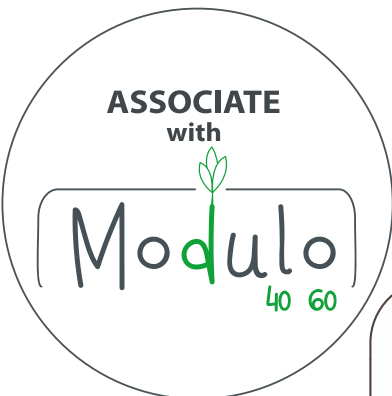
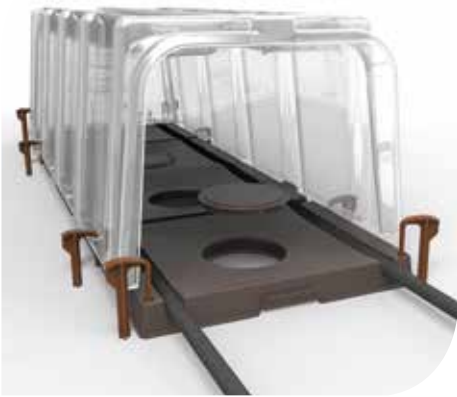

Rigid and durable mulch x2



(+ 2 plugs)



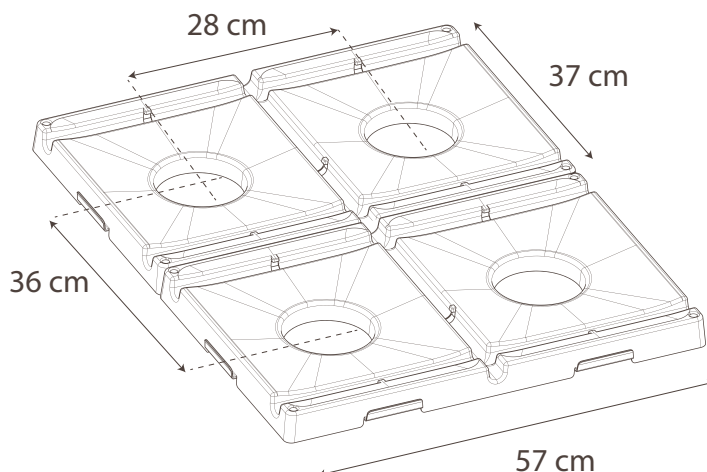

COLOURS	BROWN 
REFERENCE	PV 221 200
BARCODE	 3 557402 212007

PACKAGING	UVC PACKAGE	PACKAGE WEIGHT	PACKAGE DIMENSIONS	NO PKG / PALETTE	NO PKG / LAYER	NO LAYER / PALETTE	PALETTE WEIGHT	PALETTE DIMENSIONS	UVC / PALETTE	PACKAGING PHOTO
DISPLAY BOX 18 SETS OF 2	18	25.5 kg	60 x 40 x 105 cm	4	4	1	115 kg	120 x 80 x 117 cm	72	



Unit plate weight : 0.66 kg
 Dimensions plate : 57 cm x 37 cm x 4 cm
 Unit weight cap : 29 gr
 Dimensions cap : \varnothing 12.4 cm x 1.9 cm thickness

Material : Recycled polypropylene (75%)  
 and the presence of wood fibers of biological origin

Color : Brown

Origin : FRANCE

Guarantee : 5-year anti-UV

Period of use : ALL YEAR

Application : Position the plates under the Modulo 40 and 60 tunnels and install your watering hoses.
 1 bag of 10 pegs is enough to hold 2 to 3 ModuloPlak plates.



Scan the QR code on the back of the catalog for more information.

FABRIQUÉ EN FRANCE 



Forcing cloche



Description : Round mini-greenhouse ø 35 cm - H 30 cm.
 Lets light through.
 Integrated water collection tray + ventilation grid.
 2 holes for anchoring to ground via system of stakes.
 Rigid and stackable.

**+ 2 (INCLUSIVE)
 OFFERED
 STAKES**



Product benefits : **FORCING** the growth of salads.
 Protection against weather conditions.

Material : Polypropylene



Color : Transparent

Origin : FRANCE

Guarantee : 5-year anti-UV

Period of use : ALL YEAR

Application : ideal for individual plants (lettuce, melons, squash, geraniums, etc.).



Barcode : 3 557400 012401

Unit weight : 0.54 Kg

Unit dimensions : 35 x 35 x 30 cm

Reference : **PV 001 240**

* Also available in packs of 3, see page 13.

PACKAGING	UVC PACKAGE	PACKAGE WEIGHT	PACKAGE DIMENSIONS	NO PKG / PALETTE	NO PKG / LAYER	NO LAYER / PALETTE	PALETTE WEIGHT	PALETTE DIMENSIONS	UVC PALETTE	PACKAGING PHOTOS
DISPLAY BOX	30	17.5 kg	36x36 x 104 cm	12	6	2	225 kg	120x80 x 223 cm	360	
BOX	10	6 kg	36x36 x 55 cm	24	6	4	159 kg	120x80 x 180 cm	240	

Extension height

Description : ø 40 cm - H 32 cm. Option of extra height for cloche Modulo.
2 holes for anchoring to ground via system of stakes.
Rigid and stackable.

Product benefits : **PROTECT AND LEAVE** the tall, single plants WINTER.

Material : Polypropylene  

Color : Transparent

Origin : FRANCE

Guarantee : 5-year anti-UV

Period of use : ALL YEAR

Application : Can be used alone against the wind and the harmful.



Barcode : 3 557400 012418 

Unit weight : 0.54 Kg

Unit dimensions : 39 x 39 x 31.5 cm

Reference : PV 001 241

* Also available in packs of 3, see page 13.



PACKAGING	UVC PACKAGE	PACKAGE WEIGHT	PACKAGE DIMENSIONS	NO PKG / PALETTE	NO PKG / LAYER	NO LAYER / PALETTE	PALETTE WEIGHT	PALETTE DIMENSIONS	UVC PALETTE	PACKAGING PHOTO
BOX	10	6 kg	40 x 40 x 67 cm	18	6	3	123 kg	120x80 x180 cm	180	



Scan the QR code on the back of the catalog for more information.



Whitening cloche Modulo₃₅

Description : ø 35 cm - H 30 cm. Does not let light through. Collecting tray (2 stakes included FREE). Rigid and stackable.

Product benefits : **WHITENS** salad, endive and celery. Protection against weather conditions. Promotes the growth of single plants.

Material : Polypropylene



Color : Dark green

Origin : FRANCE

Guarantee : 5-year anti-UV

Period of use : ALL YEAR

Barcode : 3 557400 012500

Unit weight : 0.54 Kg

Unit dimensions : 35 x 35 x 30 cm

Reference : PV 001 250

Application : Ideal for making salad crispier.

**+ 2 (INCLUSIVE)
OFFERED
STAKES**



PACKAGING	UVC PACKAGE	PACKAGE WEIGHT	PACKAGE DIMENSIONS	NO PKG / PALETTE	NO PKG / LAYER	NO LAYER / PALETTE	PALETTE WEIGHT	PALETTE DIMENSIONS	UVC PALETTE	PACKAGING PHOTO
DISPLAY BOX	10	6 kg	36 x 36 x 55 cm	24	6	4	159 kg	120 x 80 x 180 cm	240	



Mini-stakes x 10 for cloche and Extension height

Description : For Modulo 35 cloche and extension height. 13 cm long, pointed tip round head, split for easy removal. Sold in bags of 10. Resistant and practical.

Product benefits : **MAINTAIN** cloche and extension height on the ground in all weathers.

Material : Polyamid



Color : Light green

Origin : FRANCE

Guarantee : 5-year anti-UV

Period of use : ALL YEAR

Barcode : 3 557400 002815

Unit weight : 0.07 Kg

Unit dimensions : 11 x 3 x 25 cm

Reference : PV 000 281

Tip : 2 mini-stakes per cloche or extension height for an optimal result.



PACKAGING	UVC PACKAGE	PACKAGE WEIGHT	PACKAGE DIMENSIONS	NO PKG PALETTE	NO PKG LAYER	NO LAYER PALETTE	PALETTE WEIGHT	PALETTE DIMENSIONS	UVC PALETTE	PACKAGING PHOTO
BOX	10	1 kg	30 x 20 x 12 cm	128	16	8	143 kg	120 x 80 x 111 cm	1280	



Forcing cloche - Set of 3

Description : Composite volume offer of 3 cloches + 6 mini-stakes

Product benefits :
DISCOUNTED PRICE in sets of 3

Barcode : 3 557400 032409

Set weight : 1.62 Kg

Set dimensions : 35 x 35 x 35 cm

Reference : **PV 003 240**

PACKAGING	UVC PACKAGE	PACKAGE WEIGHT	PACKAGE DIMENSIONS	NO PKG / PALETTE	NO PKG / LAYER	NO LAYER / PALETTE	PALETTE WEIGHT	PALETTE DIMENSIONS	UVC PALETTE	PACKAGING PHOTO
DISPLAY BOX	10	17.5 KG	36 x 36 x 104 cm	12	6	2	225 KG	120 x 80 x 223 cm	120	



Extension height - Set of 3

Description : Composite volume offer of 3 extension heights

Product benefits : **DISCOUNTED PRICE** in sets of 3

Barcode : 3 557400 032416

Unit weight : 1.62 Kg

Unit dimensions : 39 x 39 x 38.5 cm

Reference : **PV 003 241**



PACKAGING	UVC PACKAGE	PACKAGE WEIGHT	BOX WEIGHT	PACKAGE DIMENSIONS	NO PKG / PALETTE	NO PKG / LAYER	NO LAYER / PALETTE	PALETTE WEIGHT	PALETTE DIMENSIONS	UVC PALETTE	PACKAGING PHOTO
DISPLAY BOX	10	17.5 KG	1.62 KG	41 x 40.5 x 141 cm	6	6	1	120	120 x 80 x 160 cm	60	



Scan the QR code on the back of the catalog for more information.

Planting marker

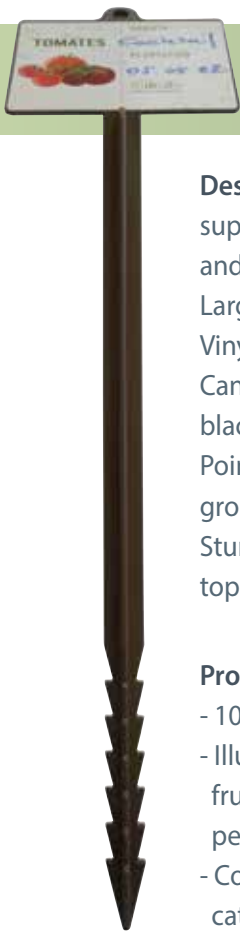

Description : Planting marker with rectangular label support to identify the different varieties of plants and the dates of sowing and/or planting. Large height 45 cm for greater visibility. Vinyl label, UV treated. Can be used with a weatherproof, hand-wipeable black felt-tip pen. Pointed tip with 5 notches for easy anchoring to the ground. Sturdy and easy to store thanks to the perforated top hole for hanging.

Product benefits :

- 100% recycled and recyclable materials
- Illustrated label with 40 varieties of vegetables, fruit or herbs (including a neutral one that can be personalised)
- Coloured border to distinguish the different categories (vegetables/fruit/aromats)



Planting marker		
	References	EAN
Vegetables		
Garlic	PV 001 462	3557400014627
Artichoke	PV 002 462	3557400024626
Aubergine	PV 003 462	3557400034625
Cardoon	PV 004 462	3557400044624
Carrot	PV 005 462	3557400054623
Cabbage / Cauliflower / Broccoli	PV 006 462	3557400064622
Cucumber / Gherkin	PV 007 462	3557400074621
Squash / Butternut / Pumpkin	PV 008 462	3557400084620
Courgette	PV 009 462	3557400094629
Endive / Chicory	PV 010 462	3557400104625
Spinach / Chard	PV 011 462	3557400114624
Fennel	PV 012 462	3557400124623
Green / Red / White bean	PV 013 462	3557400134622
Melon / Watermelon	PV 014 462	3557400144621
Turnip	PV 015 462	3557400154620
Onion / Shallot	PV 016 462	3557400164629
Potato / Sweet potato	PV 017 462	3557400174628
Pea / Sweet pea	PV 018 462	3557400184627
Leek	PV 019 462	3557400194626
Pepper / Chilli	PV 020 462	3557400204622
Radish	PV 021 462	3557400214621
Salad / Arugula	PV 022 462	3557400224620
Tomato	PV 023 462	3557400234629
Fruits		
Strawberry	PV 025 462	3557400254627
Raspberry	PV 026 462	3557400264626
Redcurrant	PV 024 462	3557400244628
Blackberry	PV 027 462	3557400274625
Blueberry	PV 028 462	3557400284624
Aromatics		
Dill / Sauerampfer	PV 029 462	3557400294623
Basil	PV 030 462	3557400304629
Chives	PV 031 462	3557400314628
Coriander	PV 032 462	3557400324627
Tarragon	PV 033 462	3557400334626
Mint	PV 034 462	3557400344625
Oregano	PV 035 462	3557400354624
Parsley	PV 036 462	3557400364623
Rosemary	PV 037 462	3557400374622
Sage	PV 038 462	3557400384621
Thyme	PV 039 462	3557400394620
Blank + felt-tip pen		
Blank label	PV 000 462	3557400004628
hand-wipeable black felt-tip pen	PV 099 462	3557400994622



Dimensions of the peg: 45 x 2 cm
Dimensions of the label: 11 x 9 cm
Peg height (without label holder): 36 cm
Weight: 47 gr

Packaging:
 Bag x 6 (identical ref.)
 Weight : 288 gr
 Bag size : 61 x 30 cm



Material: Polypropylene  
Color: Brown
Origin: FRANCE
Guarantee: 5-years anti-UV
Period of use: ALL YEAR

Application: Ideal for sowing or for differentiating varieties of tomatoes, salads, cabbage...



NEW

Standing display

Mikado



2 presentation options

- The double-sided metal grid display (from 240 to 640 planting markers)

Description :

Metal display stand on wheels with space for up to 40 removable pins for showing the 40 types of planting markers available. 2-sided display, 20 pins per side, maximum 16 planting markers possible per pin. Double-sided pancarte with explanation included. Includes merchandising strip for hanging erasable markers on the side.

Product benefits :

Put together your own assortment using the bags of 6 pieces available for each reference. Show a maximum number of products on one space-saving display.

Weight empty display : 12 kg
Dimensions : 150 x 60 cm

Display for assembly, instructions and assembly plan included (planting markers separately sold).

Barcode:



Reference : **PV 085 462**



- Calispo display for 54 planting markers

Description :

Display made on a Calispo planter with perforated cardboard insert for 36 planting markers vertically (6 rows of 6 planting markers) and 18 additional planting markers in a series. Decorative frieze included.

Product benefits :

Simple, permanent presentation and good visibility. In a small space. Mobile. Choice of assortment and restocking (bags of 6 planting markers/variety); 4 defined assortments with 54 plant tags included and varied.

Weight empty display : 6.90 kg
Dimensions : 81 x 39 x 110 cm

Calispo display is sold empty or is available in the 4 specifications below:



	SUMMER HARVEST	WINTER HARVEST	AROMATICS	BLANKS
DISPLAYS	12 Blank planting markers 12 Tomatoes planting markers 12 Salads planting markers 6 Beans planting markers 6 Strawberries planting markers 6 Courgettes planting markers	12 Blank planting markers 12 Squash planting markers 12 Potatoes planting markers 6 Leeks planting markers 6 Cabbages planting markers 6 Carots planting markers	12 Basil planting markers 12 Ciboulette planting markers 12 Mint planting markers 6 Parsley planting markers 6 Thyme planting markers 6 Rosemary planting markers	54 Blank planting markers
	REF. PV 082 462 	REF. PV 083 462 	REF. PV 084 462 	REF. PV 086 462



Scan the QR code on the back of the catalog for more information.





FABRIQUÉ EN FRANCE



Garden stake 150 Mikado

Unit weight : 0.51 Kg (150 cm)

Unit dimensions : 2.6 x 2.6 x 150 cm

COLORS	GREEN	LIME GREEN	ANTHRACIT	CHERRY
REFERENCE 150 cm	PV 150 800	PV 151 800	PV 156 800	PV 157 800
BARCODE	 3 557401 508002	 3 557401 518001	 3 557401 568006	 3 557401 578005



Description : Medium 150 cm.

Made of recycled plastic, flat and square head, pointed tip.

150 cm = 8 holes ø 7 mm for fasteners

Resistant, practical, durable.

Product benefits : **ASSISTS** growth of plants until maturity. Supports tomato plants bearing lots of fruit.

Material : Polypropylene



Color : 4 colors at choice

Origin : FRANCE

Guarantee : 5-year anti-UV

Period of use : ALL YEAR

Application : 1 color for each variety of tomato. Young trees, roses, climbers...



Accessories : garden stakes and fasteners sold separately



PACKAGING	UVC PACKAGE	PACKAGE WEIGHT	PACKAGE DIMENSIONS	NO PKG / PALETTE	NO PKG / LAYER	NO LAYER / PALETTE	PALETTE WEIGHT	PALETTE DIMENSIONS	UVC PALETTE	PACKAGING PHOTO
BOX (150 cm)	36	19.5 kg	18 x 19 x 155 cm	24	24	1	483 kg	120 x 80 x 169 cm	864	

Garden stake 180

Unit weight : 0.51 Kg (180 cm)

Unit dimensions : 2.6 x 2.6 x 180 cm



COLORS	GREEN	LIME GREEN	ANTHRACIT	CHERRY
REFERENCE 180 cm	PV 001 800	PV 101 800	PV 601 800	PV 701 800
BARCODE				

Description : Great height 180 cm.

Made of recycled plastic, flat and square head, pointed tip.

180 cm = 10 holes ø 7 mm for fasteners

Resistant, practical, durable.

DESIGNATION	REF.	BARCODE	UC-BOX
180 cm Garden stake GREEN + 4 assorted fasteners	PV 001 820		36
180 cm Garden stake LIME GREEN + 4 assorted fasteners	PV 101 820		36
180 cm Garden stake ANTHRACIT + 4 assorted fasteners	PV 601 820		36
180 cm Garden staken CHERRY + 4 assorted fasteners	PV 701 820		36



PACKAGING	UVC PACKAGE	PACKAGE WEIGHT	PACKAGE DIMENSIONS	NO PKG / PALETTE	NO PKG / LAYER	NO LAYER / PALETTE	PALETTE WEIGHT	PALETTE DIMENSIONS	UVC PALETTE	PACKAGING PHOTOS
MONOCOLOURED DISPLAY BOX SINGLE STAKE (180 cm)	72	51 kg	58 x 39 x 182 cm	4	4	1	219 kg	120 x 80 x 199 cm	288	
MONOCOLOURED DISPLAY BOX STAKE + FASTENER (180 cm)	36	28 kg	58 x 39 x 182 cm	4	4	1	127 kg	120 x 80 x 199 cm	144	
BOX (180 cm)	36	23 kg	18 x 19 x 182 cm	24	24	1	567 kg	120 x 80 x 199 cm	864	



Scan the QR code on the back of the catalog for more information.



2 L Water tray for garden stake **Mikado**

Unit Weight : 0.35 Kg

Unit dimensions : 26 x 26 x 26 cm

Description : Made from recycled plastic. Capacity **2 l**.

Central section 26 x 26 mm for connecting the garden stake.

2 removable side plugs + 1 adjustable drip-drip system.

3 long spiked feet for anchoring to ground.

Practical, sturdy and clever.

Product benefits : **REGULATES AND CONCENTRATES** water supply as per requirements. Avoids water wastage.

Material : Polypropylene



Color : 4 colors at choice

Origin : FRANCE









Guarantee : 5-year anti-UV

Period of use : ALL YEAR

Application : For use during summer, on dry ground, can be complemented with mulching at base of plants.

Accessories : garden stakes and fasteners sold separately



	GREEN	LIME GREEN	ANTHRACIT	CHERRY
COLORS				
REFERENCE	PV 001 801	PV 101 801	PV 601 801	PV 701 801
BARCODE	 3 557400 018014	 3 557401 018013	 3 557406 018018	 3 557407 018017

PACKAGING	UVC PACKAGE	PACKAGE WEIGHT	PACKAGE DIMENSIONS	NO PKG PALETTE	NO PKG LAYER	NO LAYER PALETTE	PALETTE WEIGHT	PALETTE DIMENSIONS	UVC PALETTE	PACKAGING PHOTO
BOX	12	5 kg	45 x 26 x 105 cm	12	3	4	75 kg	120 x 80 x 195 cm	144	



6 x Fasteners for garden stake

Unit weight : 0.075 Kg

Unit dimensions : 11 x 4 x 24 cm

Description : Made from recycled plastic. Length 15 cm. Open flexible ring. Sold in packs of 6 with release push button.

Quick and easy to assemble.

Product benefits : **FLEXIBLE AND ROBUST** to assist and support a growing and mature plan.

Material : Polypropylene



Color : 4 colors at choice

Origin : FRANCE

Guarantee : 5-year anti-UV

Period of use : ALL YEAR

Application : Place the ties on both sides of the stake to distribute the weight of the plant evenly.



Accessories : arden stakes and water tray sold separately

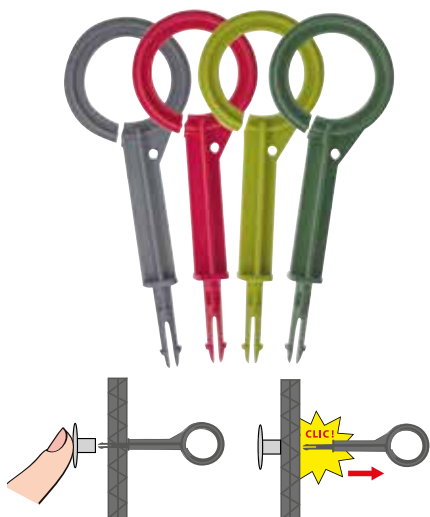

	GREEN	LIME GREEN	ANTHRACITE	CHERRY
COLORS				
REFERENCE	PV 006 802	PV 106 802	PV 601 802	PV 701 802
BARCODE				

PACKAGING	UVC PACKAGE	PACKAGE WEIGHT	PACKAGE DIMENSIONS	NO PKG / PALETTE	NO PKG / LAYER	NO LAYER / PALETTE	PALETTE WEIGHT	PALETTE DIMENSIONS	UVC PALETTE	PACKAGING PHOTO
BOX	12	1 kg	30 x 20 x 12 cm	160	16	10	175 kg	120 x 80 x 136 cm	1920	



Scan the QR code on the back of the catalog for more information.



GATHERING CROPS
CONSERVING
DECORATING
CLEARING UP
PRESERVING
CARRYING
STACKING
WASHING
STORING

4 L Basket



Description : Perforated crop and storage basket. Capacity 4 l.
Neutral base, colored folding legs / handles.
Handy, functional, aesthetic and practical.

Product benefits : **REDUCE** lifting and **PRESERVE** your crop.
For collecting garden crops but also useful around the house.
Folding, stackable, easy to clean and store away.

Material : Polypropylene



Color : 3 new colors at choice

Origin : FRANCE

Guarantee : 5-year anti-UV

Period of use : ALL YEAR

Application : Easy to take in hand, ideal for the children.
To use in Kajo 15 l. stacked-shelving way.



Harvest basket 4 L

Kajo®



Unit weight : 0.38 Kg

Unit dimensions : 24 x 20 x 15 cm



COLORS	GREY	TAUPE	GREEN	MIXED 3 COLORS BOX 30 KAJO 4 L
REFERENCE	PV 004 922	PV 004 941	PV 004 942	PV 304 922
BARCODE				

PACKAGING	UVC / PACKAGE	PACKAGE WEIGHT	PACKAGE DIMENSIONS	NO PKG / PALETTE	NO PKG / LAYER	NO LAYER / PALETTE	PALETTE WEIGHT	PALETTE DIMENSIONS	UVC / PALETTE	PACKAGING PHOTOS
MONO COLORED BOX	10	4.10 kg	25 x 21 x 57	45	15	3	195 kg	120 x 80 x 183	450	
MIX DISPLAY BOX STAND 3 COLORS	30	12.6 kg	75 x 22 x 57	15	5	3	195 kg	120 x 80 x 183	450	



Scan the QR code on the back of the catalog for more information.

FABRIQUÉ EN FRANCE



GATHERING CROPS
 CONSERVING
 DECORATING
 CLEARING UP
 PRESERVING
 CARRYING
 STACKING
 WASHING
 STORING

15 L Basket **Kajo**[®]



Description : Perforated crop and storage **basket**. Capacity 15 l.
 Neutral base, colored folding legs / handles.
 Handy, functional, aesthetic and practical.

Product benefits : **REDUCE** lifting and **PRESERVE** your crop. For collecting garden crops but also useful around the house. Folding, stackable, easy to clean and store away.

Material : Polypropylene



Color : 3 colors at choice

Origin : FRANCE

Guarantee : 5-years anti-UV

Period of use : ALL YEAR

Application : Once you have gathered your crops, stack your Kajo baskets for easy storage. Possibility to put 2 Kajo 4 l in 1 Kajo 15 l.

NEW

Combine 1 Kajo 15 l. with the **Bike Rack** to carry your lunch, sports or office equipment, shopping or 2 Kajo 15 l. with the **Kaba** to carry 2 full baskets (up to about 5kg each) 2 filled baskets (up to 5 kg each).



Harvest basket 15 L

Unit weight : 0.85 Kg

Unit dimensions : L 48 x l 29 x h 20 cm



COLORS	GREY	TAUPE	GREEN
			
REFERENCE	PV 001 922	PV 001 941	PV 001 942
BARCODE	 3 557400 019226	 3 557400 019417	 3 557400 019424

PACKAGING	UVC / PACKAGE	PACKAGE WEIGHT	PACKAGE DIMENSIONS	NO PKG PALETTE	NO PKG LAYER	NO LAYER PALETTE	PALETTE WEIGHT	PALETTE DIMENSIONS	UVC / PALETTE	PACKAGING PHOTO
DISPLAY MONO COLORED BOX	10	9.5 kg	50 x 31 x 59 cm	18	6	3	170 kg	120 x 80 x 189 cm	180	



Scan the QR code on the back of the catalog for more information.



GATHERING CROPS
 CONSERVING
 DECORATING
 CLEARING UP
 PRESERVING
 CARRYING
 STACKING
 WASHING
 STORING

20 L Basket **Kajo**[®]



Description : Perforated crop and storage basket. Capacity 20 l.
 Neutral base, colored folding legs / handles.
 Handy, functional, aesthetic and practical.

Product benefits : **REDUCE** lifting and **PRESERVE** your crop.
 For collecting garden crops but also useful around the house.
 Folding, stackable, easy to clean and store away.



Material : Polypropylene



Color : 3 colors at choice

Origin : FRANCE

Guarantee : 5-year anti-UV

Period of use : ALL YEAR



Application : Crate format, perfect for storage.



Harvest basket 20 L

Kajo[®]



Unit weight : 1.25 Kg

Unit dimensions : 58 x 38 x 15 cm



COLORS	GREY	TAUPE	GREEN
REFERENCE	PV 020 922	PV 020 941	PV 020 942
BARCODE	 3 557400 209221	 3 557400 209412	 3 557400 209429

PACKAGING	UVC / PACKAGE	PACKAGE WEIGHT	PACKAGE DIMENSIONS	NO PKG PALETTE	NO PKG LAYER	NO LAYER PALETTE	PALETTE WEIGHT	PALETTE DIMENSIONS	UVC / PALETTE	PACKAGING PHOTO
DISPLAY MONO COLORED BOX	10	14.4 kg	60 x 40 x 56.5	12	4	3	171 kg	120 x 80 x 182	120	



Scan the QR code on the back of the catalog for more information.

FABRIQUÉ EN FRANCE



Wheeled trolley

Kaba for **Kajo** 15 L

Description : Wheeled trolley to carry 2 Kajo 15 l. baskets.

Light, handy, foldable and compact.

Height-adjustable handle, folding stand for easy storage and installation in a car boot or a cupboard, and the pocket is removable.

Product benefits : EASY to move loaded Kajo baskets (up to about 5 kg per Kajo).

Comfortable, functional and space-saving thanks to the foldable stand and handle.

Multiple uses : in the garden, at the market, shopping, at the beach, on a picnic, at home...

Unit weight : 2.65 kg

Dimensions max. height : 107.6 x 48.4 x 46.7 cm

Dimensions min. height : 77.8 x 48.4 x 46.7 cm

Dimensions when folded : 78 x 48.4 x 19 cm

Material : Polypropylene -  ABS (wheel clips and lock) - EVA (tyres)

Color : 6 mixed colors at choice

Origin : FRANCE

Guarantee : 5-year anti-UV

Periode of use : ALL YEAR

Application : Combine and carry your Kajo 15 l. baskets (sold separately), adjust the height of the handle according to your size for a better comfort.



ASSOCIATE
with
Kajo 15L



Wheeled trolley



voor **Kajo**® 15 L



COLORS	GREY / CHERRY	GREY / LIME GREEN	GREY / TURQUOISE
REFERENCE	PV 101 925	PV 101 926	PV 101 927
BARCODE	 3 557401 019256	 3 557401 019263	 3 557401 019270

COLORS	GREY / LIGHT GREY	TAUPE / BEIGE	OLIVE GREEN / ALMOND GREEN
REFERENCE	PV 101 922	PV 101 941	PV 101 942
BARCODE	 3 557401 019225	 3 557401 019416	 3 557401 019423



NON-CONTRACTUAL PHOTOS

PACKAGING	UVC PACKAGE	PACKAGE WEIGHT	PACKAGE DIMENSIONS	NO PKG / PALETTE	NO PKG / LAYER	NO LAYER / PALETTE	PALETTE WEIGHT	PALETTE DIMENSIONS	UVC / PALETTE	PACKAGING PHOTO
BOX	1	3.10 kg	45 x 15 x 73 cm	32	8	4	100 kg	120 x 80 x 200 cm	32	



Scan the QR code on the back of the catalog for more information.

FABRIQUÉ EN FRANCE

Bike basket holder

for **Kajo** 15 L



Description : Bike basket holder for carrying 1 Kajo 15 l. basket on the handlebars of a bicycle.

Fits most handlebars thanks to the adjustable spacer

(ø handlebars : 21-24 mm/ 32 mm).

Maximum basket load: 5 kg.

Product benefits : CARRY your belongings in your Kajo 15 l. basket on the front of your bike, easy to assemble and disassemble, removable basket thanks to the clip lock.

Unit weight : 0.4 kg

Dimensions : 11.5 x 20 x 15.6 cm

Material : Polypropylene

Color : Anthracit grey

Origin : FRANCE

Guarantee : 5-year anti-UV

Period of use : ALL YEAR



ASSOCIATE
with
Kajo 15L

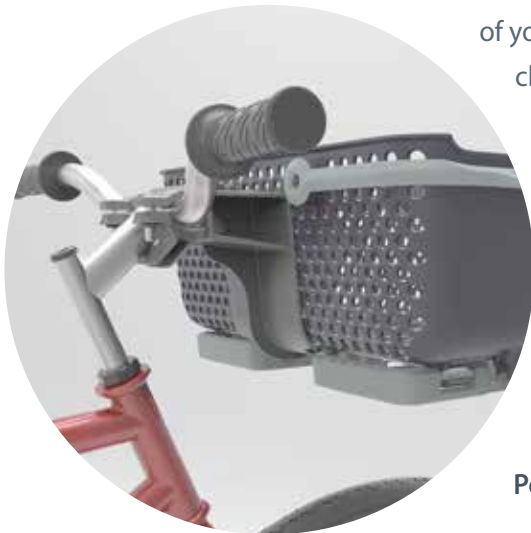

Application : Carry your Kajo 15 l. basket (sold separately) for your walks, shopping, picnics, city trips...



COLOR	ANTHRACIT GREY 
REFERENCE	PV 201 920
BARCODE	 3 557402 019200

PACKAGING	UVC PACKAGE	PACKAGE WEIGHT	PACKAGE DIMENSIONS	NO PKG / PALETTE	NO PKG / LAYER	NO LAYER / PALETTE	PALETTE WEIGHT	PALETTE DIMENSIONS	UVC / PALETTE	PACKAGING PHOTO
BOX	1	0.3 kg	25 x 12 x 11 cm	240	30	8	108 kg	120 x 80 x 100 cm	240	



Compost bucket

Kajo



Description : Organic waste collection bucket (5 l. capacity) to collect your waste in the kitchen and limit trips to the outside composter.

Equipped with an active carbon filter to stop odours (3 months protection, washable or renewable) and a hermetic lid to prevent the proliferation of insects.

Product benefits :

- Recycled and recyclable materials,
- Design for easy cleaning (rounded corners)
- Anti-odour carbon filter (replaceable and/or washable)
- Dishwasher safe

Unit weight : 0,46 kg

Dimensions : 18.5 cm x 18.5 cm x 22 cm

Volume : 5 l.

Bucket Barcode :  7 610316 823618
Reference : 4005.55 MV

Filter x 2 Barcode :  3 557404 005560
Reference : PV 400 556



Material : Polypropylene   (100% recycled material)

Color : Black/grey (colors may vary depending on the source of the materials used)

Origin : SWITZERLAND

Guarantee : 5-year anti-UV

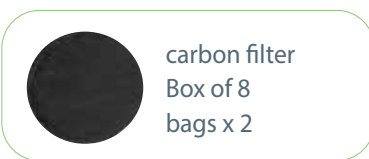

Period of use : ALL YEAR



Application : Contemporary design that adapts to all interiors, its dimensions Its dimensions allow a daily collection of your organic waste.

Depending on the waste collected, empty your bucket in the composter or in the henhouse.



PACKAGING	UVC / PACKAGE	PACKAGE WEIGHT	PACKAGE DIMENSIONS	NO PKG / PALETTE	NO PKG / LAYER	NO LAYER / PALETTE	PALETTE WEIGHT	PALETTE DIMENSIONS	UVC / PALETTE	PACKAGING PHOTOS
DISPLAY BOX	24	12.40 kg	59 x 40 x 95 cm	8	4	2	114 kg	120 x 80 x 205 cm	192	
BOX	8	4.48 kg	40 x 40 x 41 cm	30	6	5	150 kg	120 x 80 x 215 cm	240	



Scan the QR code on the back of the catalog for more information.



40 L Double window box

40 L Double window box *Mini Junior*

CALIPSO JUNIOR PLANTER	GREEN	WEIGHT / DIMENSIONS
<p><i>Mini Junior</i></p> <p>(Height 50 cm) Low planter Double tray 40 L + 4 removable low feet</p>	<p>2 garden tools + 1 basket Kajo 4L</p>	<p>Weight : 6.50 kg</p> <p>Dimensions : 81 x 39 x 50 cm</p>
REFERENCE	PV 006 531	
BARCODE	<p>3 557400 065315</p>	



Description : An **outer tray** with 9 litres of water storage and a perforated **inner tray** to allow the right root growth. Ventilation and watering chimney with water level control and water level control system too full.

Short feet (or long on other models) removable and perfectly adapted to children.

Product benefits INGENIOUS AND INNOVATIVE : allowing a perfect balance between the elements **earth, air, water and heat** necessary for the proper development of plants, herbs, seedlings, flowers, etc.

Works like a water table.

- Easy to handle harvest basket for collecting (tomatoes, eggs, Easter eggs, red fruit, dried fruit, shells, mushrooms Easter eggs, red fruit, dried fruit, shells, mushrooms...). Colorful, handy, functional, aesthetic, practical and stackable. For picking in the garden, but also for the whole house.

- 2 garden tools (transplanter + claw) to introduce your children to the fun of gardening. Made of strong polypropylene.

SELF-SUFFICIENT water management.
ISOLATED from sun and against cold (double wall with air circulation).
MULTIPURPOSE

Material : Polypropylene

Color : 1 color green

Origin : FRANCE

Guarantee : 5-years anti-UV

Period of use : ALL YEAR



Ideal for children :

- Low planter adapted to the size of the children.
- Colourful and customizable with a double decorative self-adhesive frieze offered (to be glued on the lower part of the tray).
- Included : 1 basket 4 l. + 2 garden tools (transplanter + claw).

Application : When the plants mature, fill the water tank and simply relax, your planter is autonomous for several days.



40 L Planter



40 L Planter *Maxi* BASIC

Description : A **rigid tray** to accommodate 10 l. of clay balls and 30 l. of soil for the cultivation of vegetables, seedlings, flowers and herbs.

Product benefits **INGENIOUS AND INNOVATIVE :**

- REMOVABLE FEET allowing you to turn your planter into a flowering or seeding bin.
- AMOVIBLE BUCKET on the side for easy discharge of excess water.
- ISOLATED against cold from the ground.
- MULTIPURPOSE

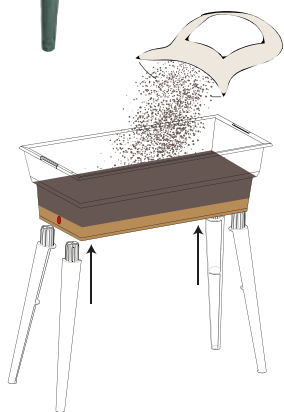

Material : Polypropylene  

Color : 3 colors at choice

Origin : FRANCE





Guarantee : 5-years anti-UV

Period of use : ALL YEAR



Application : Put a layer of clay beads underneath (about 5 cm/10 l.) then fill with soil (30 l.).



MODELS	GREY	TAUPE	GREEN	WEIGHT / DIMENSIONS
<p><i>Maxi</i> BASIC</p> <p>High planter tray 40L. + 4 removable high feet</p>				<p>Weight : 4.36 kg</p> <p>Dimensions : 81 x 39 x 80 cm</p>
	REF. PV 007 520	REF. PV 007 530	REF. PV 007 550	
	 3 557400 075 208	 3 557400 075 307	 3 557400 075 505	



can the QR code on the back of the catalog for more information.

FABRIQUÉ EN FRANCE 



**EXCLUSIVITY
BAC WITH
WATER RESERVE 9 L**



40 L Double window box

Description : An **outer container** with water reserve (9 l.) for the water-bearing roots and an **inner perforated container** (with rounded corners) for the feeder roots. Aeration and watering chimney with water level control and overflow system. Removable feet. Lower tray cut-out for easy handling of the upper tray (transplanting seedlings in the garden and checking the roots).

Product benefits : **INGENIOUS AND INNOVATIVE** allowing a perfect **balance** between the elements **earth, air, water and heat** necessary for the proper development of plants, herbs, seedlings, flowers, etc. Works like a groundwater table.

SELF-SUFFICIENT water management.

INSULATED from sun and against cold (double wall with air circulation).

MULTIPURPOSE

Material : Polypropylene



Color : 3 colors at choice

Origin : FRANCE

Guarantee : 5-year anti-UV

Period of use : ALL YEAR

Accessories : Partitions and bell sold separately for mini and maxi versions

Application : Fill the water storage and simply relax, your planter is self.

MODELS	GREY	TAUPE	GREEN	UNIT PACKAGE	UVC / PALETTE
Maxi (Dim. L 81 x l 39 x H 80 cm Weight : 6.80 kg) Double high 40L window box + shelf + 4 removable high feet				/	/
	REF. PV 002 528	REF. PV 002 530	REF. PV 002 531	82 x 40 x 28 cm	21
				/	/

MODELS	REFERENCE	BARCODE	PACKAGING	UVC / PACKAGE	PACKAGE WEIGHT	PACKAGE DIMENSIONS
 OPTION PARTITIONS SOWING (GREY) 32 SHELVES Dim. : 70 x 8 x 13 cm - Weight : 1.25 kg	PV 004 503		BOX	10	13 kg	62 x 26 x 18.5 cm
 OPTION CLOCHE (TRANSPARENT) Dim. : 82 x 40 x 22 cm - Weight : 1.50 kg	PV 005 503		BOX	10	16 kg	83 x 41 x 58 cm

40 L Double window box



40 L Double window box



Product benefits of the Combi version :

- Create up to 32 seedlings with the modular partitions
- Ventilated protective cover
- 2 side hinges to hold the cover in place
- Handle on the front for easy opening of the cover



MODELS	GREY	TAUPE	GREEN	UNIT PACKAGE	UVC/ PALETTE
Combi (Dim. L 81 x l 39 x H 80 cm Weight : 9.850 kg) Double high 40L. window box mini- greenhouse seed dividers + shelf + cloche + 4 removable high feet				/	/
	REF. PV 003 528	REF. PV 003 530	REF. PV 003 531	82 x 41 x 32 cm	20
				/	/



can the QR code on the back of the catalog for more information.



Garden tools kit



Description of the kit :

1 TRANSPLANTER for planting, transplanting, pricking out, mixing or spreading soil. Curved shape to allow a leverage effect in order to take your plant out of the ground easily and without disturbing the roots.

1 GARDEN CLAW with 3 tines for loosening, aerating and weeding.

Allows you to soften and hoe the soil to facilitate sowing or planting and their acclimatisation in your window box, pot or vegetable garden.

1 HOE for weeding, loosening the soil, tilling vegetables, digging the soil. 19 cm handle with a pointed end to break the earth's crust that forms under the effect of rain and watering, a flat and sharp part to cut the plants or lift the earth. Hoeing is a fundamental part of gardening to limit watering, ventilate the soil and air and eliminate weeds.



Product benefits : **LIGHT AND FUNCTIONAL TOOLS** made of recycled plastic (does not rust), adapted to the morphology of adults and children. Better working comfort, less risk for the user. Hanging hole for easy storage and shelving.

Unit weights : Transplanter 33 gr - garden claw 36 gr - hose 62 gr

Transplanter dimensions : 21.6 x 5.4 cm

Garden claw dimensions : 18.6 x 5.7 cm

Hose dimensions : 20 x 14.7 cm

Material : Polypropylene



Colors : 3 colors at choice (coordinated with the Kajo and Calipso Junior ranges)

Origin : FRANCE

Guarantee : 5-years anti-UV

Period of use : ALL YEAR

Application : Combine with your Calipso planters for better work in the soil. our children can also carry them in the matching Kajo 4 l. baskets.



Garden tools kit



COLORS	GREY	TAUPE	GREEN
REFERENCE	PV 116 521	PV 116 526	PV 116 527
BARCODE	 3 557401 165212	 3 557401 165267	 3 557401 165274



PACKAGING	UVC PACKAGE	PACKAGE WEIGHT	PACKAGE DIMENSIONS	NO PKG / PALETTE	NO PKG / LAYER	NO LAYER / PALETTE	PALETTE WEIGHT	PALETTE DIMENSIONS	UVC / PALETTE	PACKAGING PHOTO
BOX	12 KITS	1.863 kg	36 x 36 x 13 cm	72	6	12	149 kg	120 x 80 x 171 cm	864	



can the QR code on the back of the catalog for more information.



Description : **Foot elevation kits** for Calipso Maxi - Combi planters including :
4 leg extensions to raise your planter (2 heights: + 20 cm and + 10 cm)
+ 2 support brackets to reposition the work shelf (sold with the planter).

Product benefits : Makes it easier for people with reduced mobility (wheelchair) and tall people to Mobility (wheelchair) and tall people.
Provides more light on balconies. Visual comfort and practicality.
The brackets allow the work shelf to be repositioned in height to make way for a wheelchair.

Kit +10 cm

Unit weight : 0.84 kg

Dimensions : H 24 x 5 cm

Kit +20 cm

Unit weight : 1.03 kg

Dimensions : H 33.5 x 5 cm

Material : Polypropylene



Color : Anthracit grey

Origine : FRANCE

Guarantee : 5 years anti-UV

Period of use : ALL YEAR

Application : Place the shelf on the front or back of your Maxi planter and on the front of your Combi planter.



Elevation kit for planter

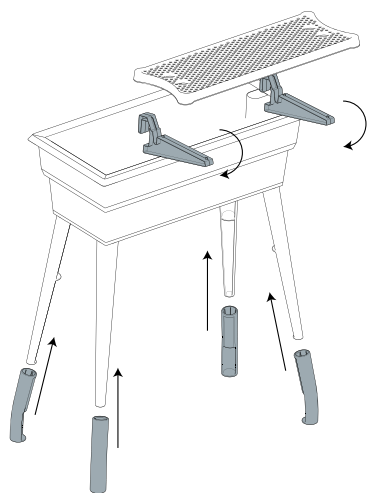
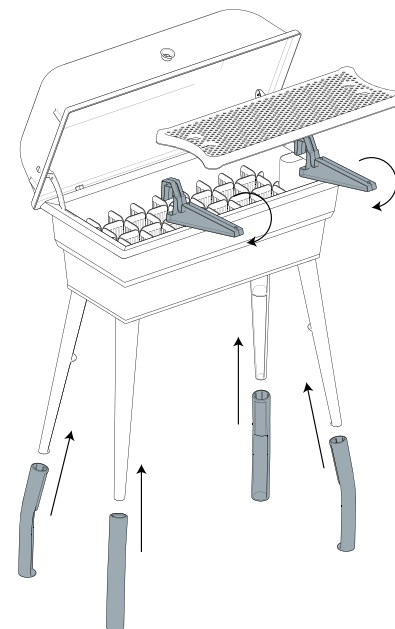

	KIT +10 cm	KIT +20 cm
COLORS		
REFERENCE	PV 010 520	PV 020 520
BARCODE	3 557400 105202	3 557400 205209

	PACKAGING	UVC PACKAGE	PACKAGE WEIGHT	PACKAGE DIMENSIONS	NO PKG / PALETTE	NO PKG / LAYER	NO LAYER / PALETTE	PALETTE WEIGHT	PALETTE DIMENSIONS	UVC PALETTE	PACKAGING PHOTO
KIT + 10cm	BOX	10	8.90 kg	60 x 40 x 30 cm	24	4	6	223.20 kg	120 x 80 x 190 cm	240	
KIT + 20cm	BOX	10	10.80 kg	60 x 40 x 30 cm	24	4	6	268.80 kg	120 x 80 x 190 cm	240	



can the QR code on the back of the catalog for more information.



Robust frame designed by a professional for greenhouses

Diameter galvanized steel 32 mm
thickness 1.5 mm

Plastic cover film transparent plastic film
5 YEAR WARRANTY ANTI UV
and more than 90% light transmission

Accessories and after-sales service

PE repair adhesive

Steel clips ø 32 mm



Greenhouse tarpaulins available Shade foils
and tarpaulins in rolls or cut to size



Strong ground anchoring

System used by professionals

Modular conservatory :
Extra length 1.50 m and/or extra door



Adjustable shade sail



Width greenhouse 2 m
6 m² model / 1 door with zipper



Width greenhouse 3 m
9 m² model / 1 door with zipper

For technical information about the greenhouses and accessories, consult the **RICHEL** catalog
or our website www.mvindustrie.fr

French manufacture and after sales service. Warehouses in France near you.



Width greenhouse 3 m
9 m² model / 1 revolving door



Width greenhouse 3 m
13.5 m² model / 2 doors with zipper



Width greenhouse 3 m
18 m² model / 2 revolving doors



Width greenhouse 3 m
18 m² model / 2 doors with zipper



Width greenhouse 4.5 m
Model 20,25 m² / 1 revolving door



Width greenhouse 4.5 m
27 m² model / 2 revolving doors



can the QR code on the back of the catalog for more information.

487 Allée des Platanes
Z.A Champgrand
26270 Loriol-sur-Drôme
FRANCE

Tél. +33 (0)4 75 61 40 70

www.mvindustrie.fr

info@mvindustrie.fr

commandes@mvindustrie.fr

**FABRIQUÉ
EN FRANCE**



French manufacturing
of gardening equipment

www.mvindustrie.fr

Commercial France Contact :

Mathieu BEAUDOUIN

+33 (0)6 84 66 66 24

mathieu.beaudouin@mvindustrie.fr

Commercial Export Contact :

Gwendoline LEGENDRE

gwen.legendre@mvindustrie.fr

Scan this QR code
and find us
www.mvindustrie.fr



 MV Industrie

 @mvindustrie